

THE INFORMATION CONTAINED IN THIS DRAWING IS THE SOLE PROPERTY OF U.S. FOUNDRY & MANUFACTURING CORP. ANY REPRODUCTION IN PART OR AS A WHOLE WITHOUT THE WRITTEN PERMISSION OF U.S. FOUNDRY & MANUFACTURING CORP. IS PROHIBITED. U.S. FOUNDRY & MANUFACTURING CORP. RESERVES THE RIGHT TO MAKE MODIFICATIONS TO DESIGN WITHOUT PRIOR NOTICE. DRAWING IS UNCONTROLLED WHEN PRINTED. WEIGHTS AND DIMENSIONS ARE PROVIDED FOR REFERENCE ONLY © 2015 US FOUNDRY AN EAGLE MANUFACTURING COMPANY

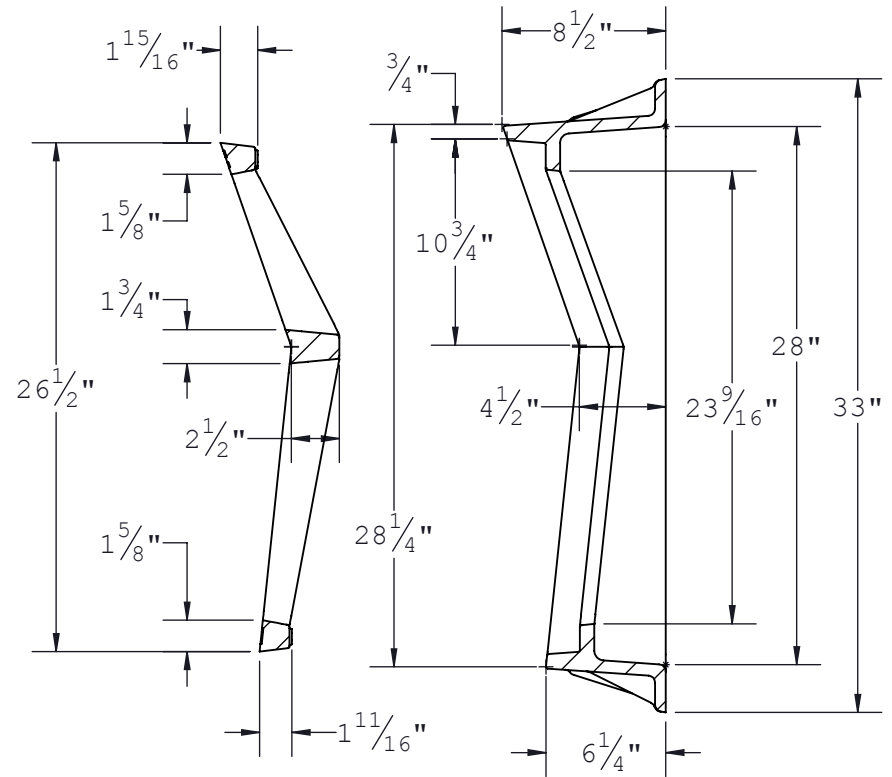

SECTION B-B

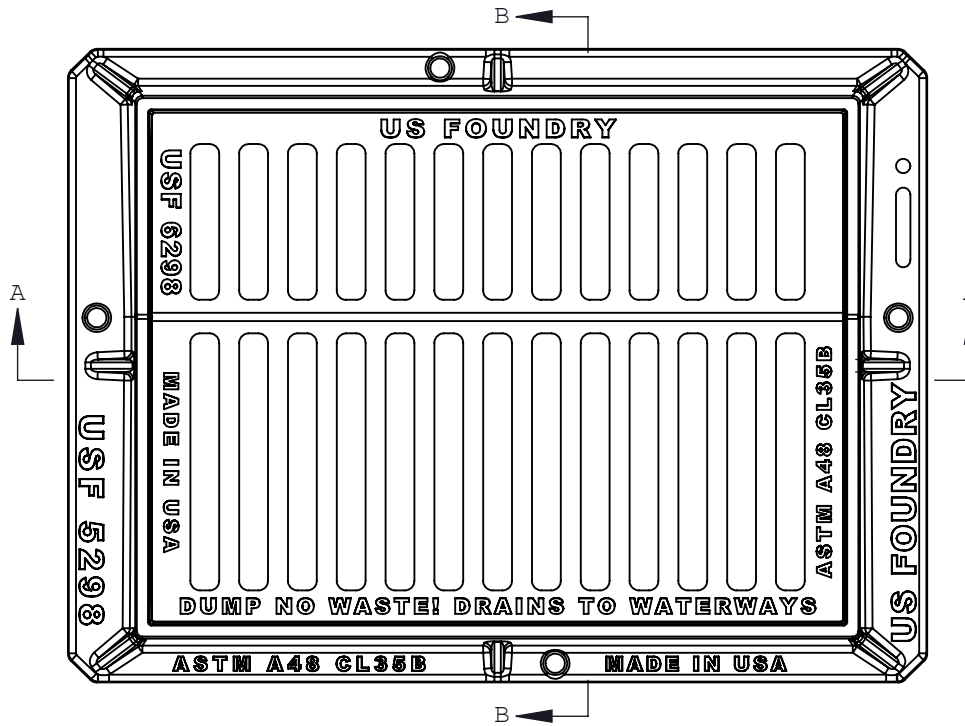
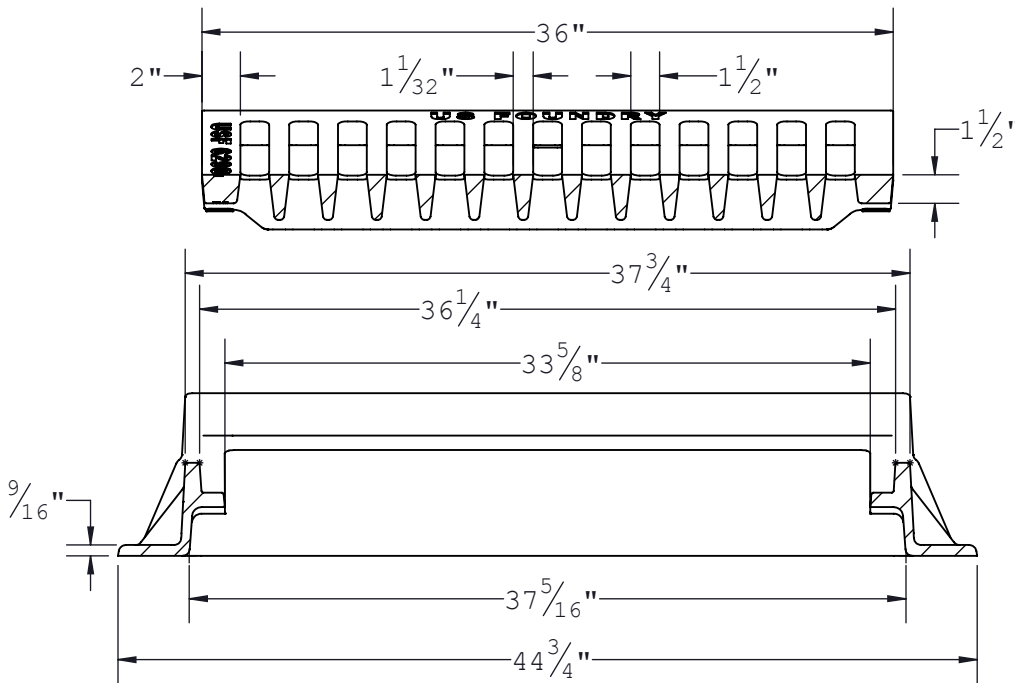

SECTION A-A

8351 NW 93rd Street
 Medley, FL, 33166-2025
 ph: 1-800-432-9709
 fax: 305-887-9429
 www.usfoundry.com
 AN EAGLE MANUFACTURING COMPANY © 2015 All Rights Reserved

USF 5298 Frame & 6298 Grate

LOAD CLASSIFICATION:	Heavy Duty	FLOW AREA:	424.5
MATERIAL:	Gray Cast Iron	ASTM-A48 Class 35B	
ITEM:	BAAN #	DRAWING	
Frame	8030402	DATE	9/25/2014
Grate	8076798	DRAWN BY	ULS/OD
Assembly	8040190	QUOTE #	4149
REV	0	DATE	REV BY

Customer Drawing

For a complete product offering please visit us at www.usfoundry.com