

H:9B:CFA5HC B7CBH5B98 B H:68F5K B: 4GH:9GC@DFCD9FMC: 1'G':CIB8FM' A5BI:57HF B: 7CFD'5BMF9DFC8I7HC B B D5FH
 CF5G5 K <C@K H:C1HH:9K F#H9B D9FA GGCBC: 1'G':CIB8FM' A5BI:57HF B: 7CFD'6DFC-6H98'1'G':CIB8FM' A5BI:57HF B:
 7CFD'F99FJ 9GH:9F <HC A579A C8=75HC BGHC 89G= B K H:C1HDF:CFBCH7 9'8F5K B: 4I B7CBHC@98 K <9B DF:8H98'K 9= <HG
 5B8 8A 9BGC BG5F9DFCJ 498:CF F9:9F 9B79CB@M# &5%(1'G':CIB8FM5B'95: @9A5BI:57HF B: 7CAD5BM

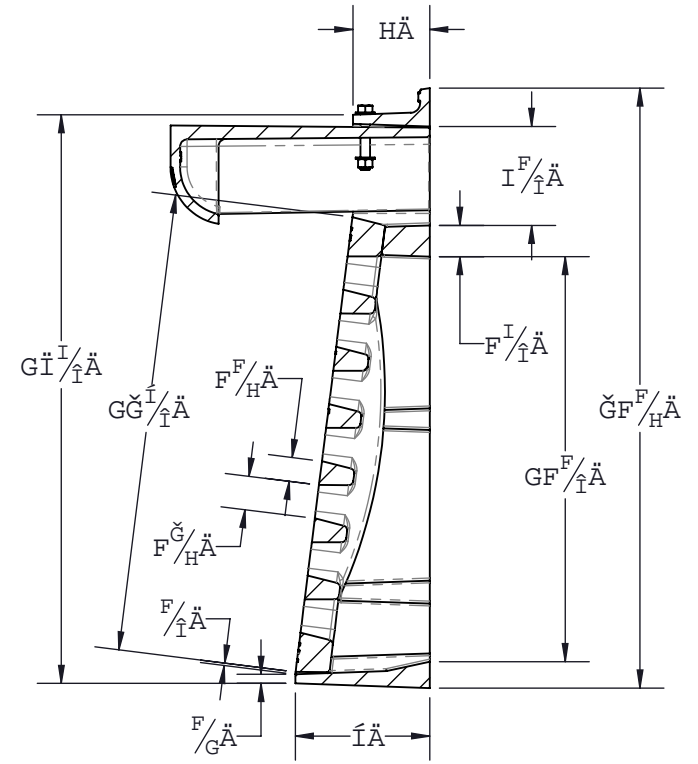

UÓÓÚØŠŠÁÑĚÑ

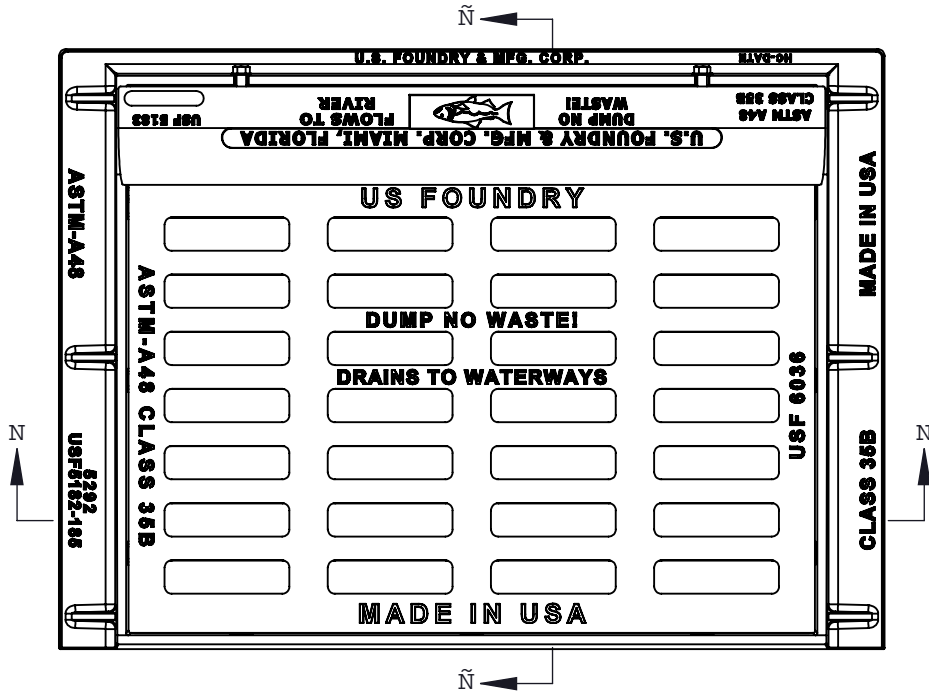
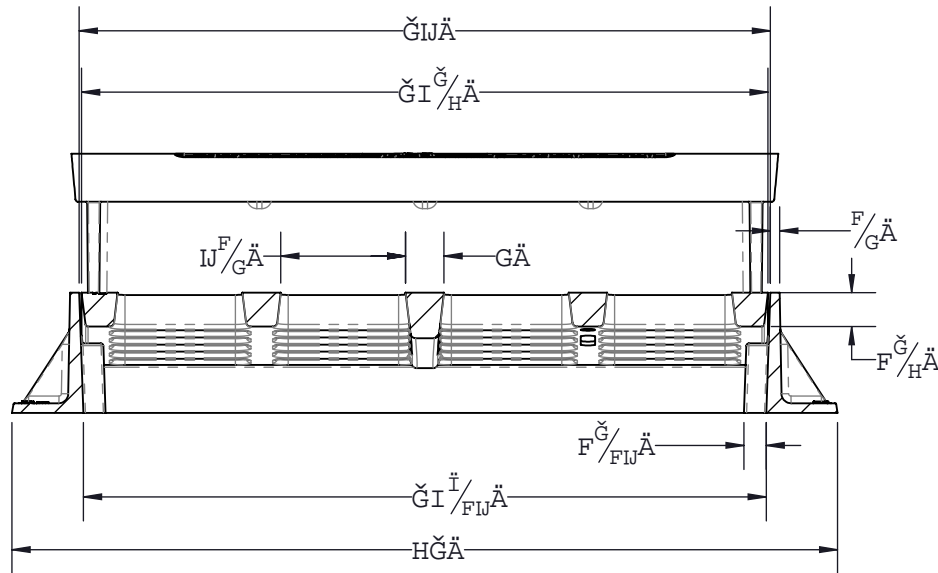

UÓÓÚØŠŠÁÑĚÑ



') %BK ' -' fX GhtYyh
 A YX'Ymž: @' ' %* ! &\$&
 d\ . %d, \$\$! (' &! - + \$-
 žU . ' \$) ! , , +! - (&-
 k k k " i gžci bXfmW@a
 ¥ ' &\$%(' 5' ' F] [\ hg FYygfj YX

I G: ') &- %: fUa Y ! <ccX / '* \$' *'; fUHY

© 58 7 6GG=75HC B.		J gcx{ 'F w{ : © K '5F95.	53704kp
A 5HPF-5@		I tc{ 'Ecu'Kqp CUVO/C6: 'Encu'57D	
#9A.	655B'	8F5K B:	
: fUa Y	: 252774		
; fUHY	: 299326	85HP	7434236
<ccX	: 282232		
5gg'a V'm	: 272463	8F5K B'6M	
		WNU	
F9J	2 85HP	F9J 6M	E1CH9.
		62: 8.6363	

7i gftca Yf.8fuk]bl