

THE INFORMATION CONTAINED IN THIS DRAWING IS THE SOLE PROPERTY OF U.S. FOUNDRY & MANUFACTURING CORP. ANY REPRODUCTION IN PART OR AS A WHOLE WITHOUT THE WRITTEN PERMISSION OF U.S. FOUNDRY & MANUFACTURING CORP. IS PROHIBITED. U.S. FOUNDRY & MANUFACTURING CORP. RESERVES THE RIGHT TO MAKE MODIFICATIONS TO DESIGN WITHOUT PRIOR NOTICE. DRAWING IS UNCONTROLLED WHEN PRINTED. WEIGHTS AND DIMENSIONS ARE PROVIDED FOR REFERENCE ONLY © 2014 US FOUNDRY AN EAGLE MANUFACTURING COMPANY

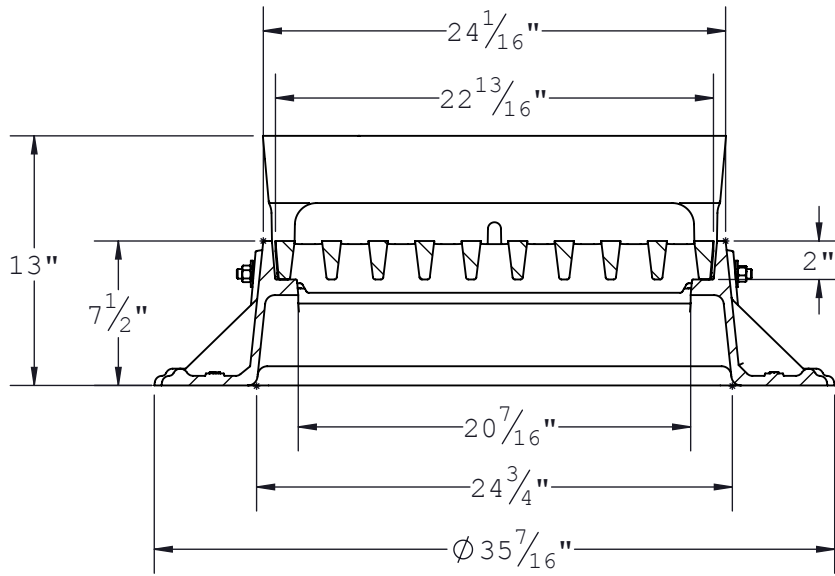

SECTION A-A

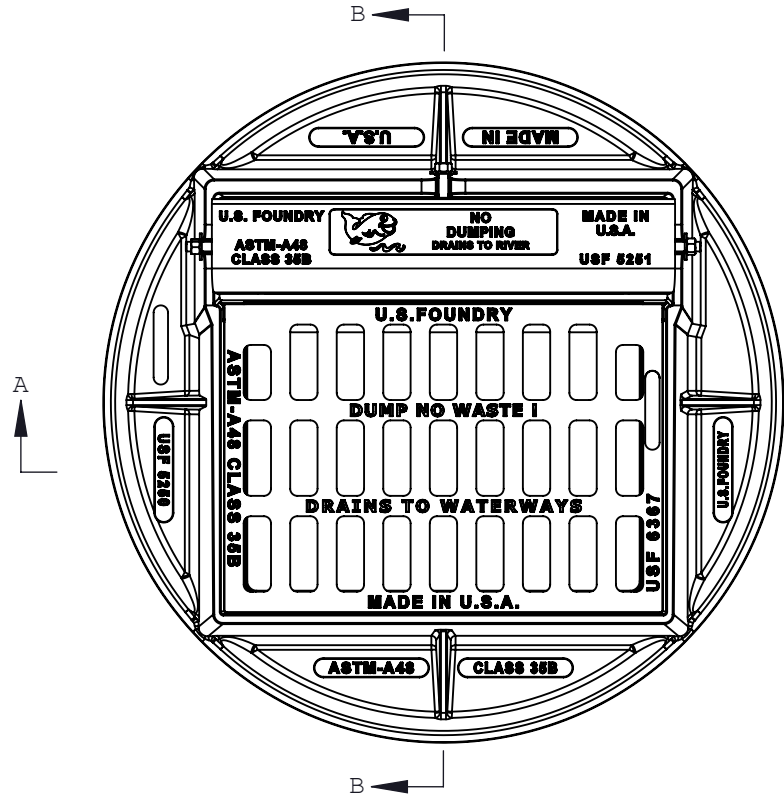
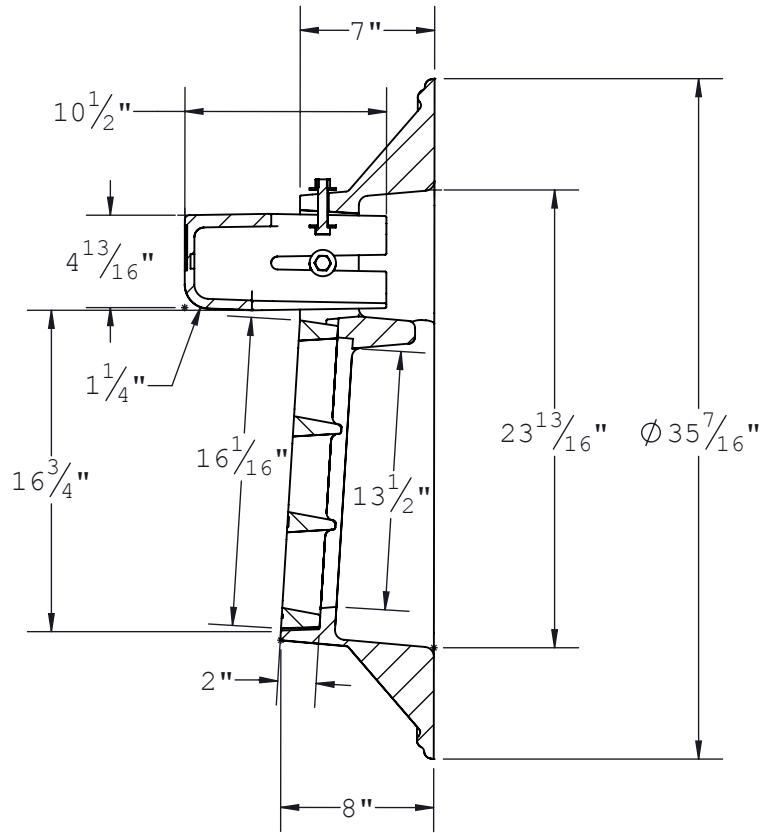

SECTION B-B



**US FOUNDRY**

AN EAGLE MANUFACTURING COMPANY © 2014 All Rights Reserved

8351 NW 93rd Street  
Medley, FL, 33166-2025  
ph: 1-800-432-9709  
fax: 305-887-9429  
www.usfoundry.com

**USF 5252 Frame-Hood & 6367 Grate**

LOAD CLASSIFICATION:	Heavy Duty	FLOW AREA:	145 in <sup>2</sup>
MATERIAL:	Gray Cast Iron ASTM-A48 Class 35B		
ITEM:	BAAN #	DRAWING	
Frame	8030398	DATE 01-03-2013	
Grate	8070792		
Hood	8060090	DRAWN BY ULS/AB	
Assembly	8050202		

REV	A	DATE	01-21-2013	REV BY	ULS	QUOTE #	3390
-----	---	------	------------	--------	-----	---------	------

Customer Drawing