

(2) DROP HANDLE

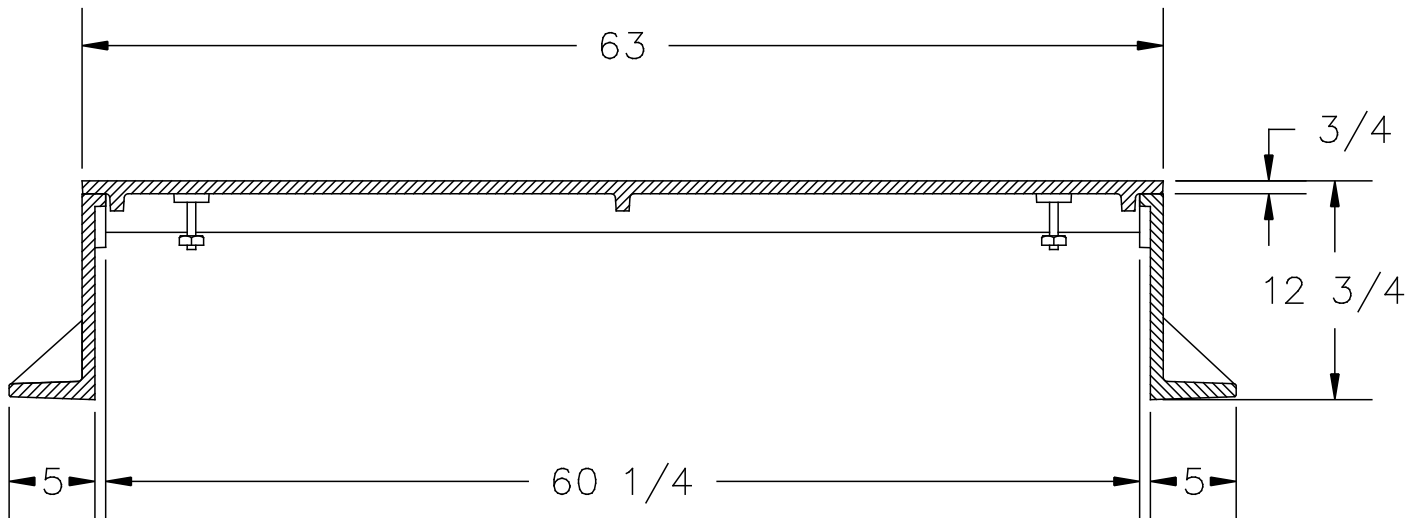
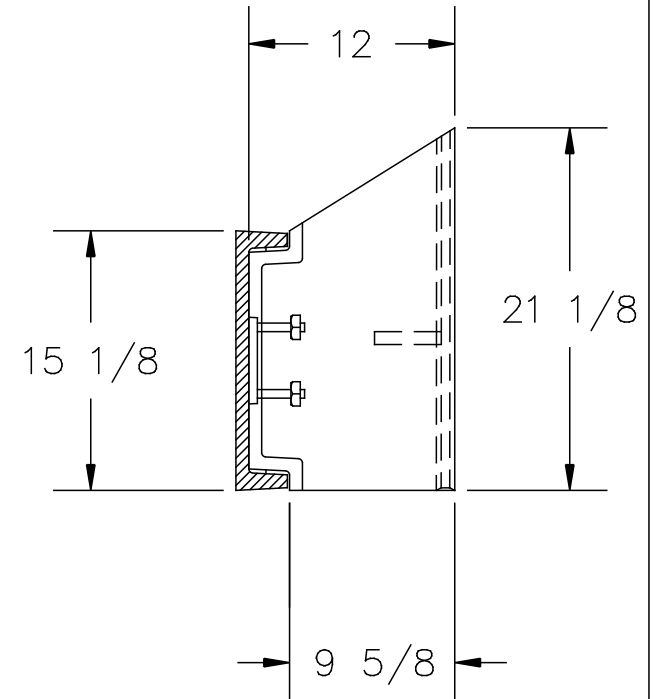

NOTES:

- 1- MATERIAL; ASTM-A48 CLASS 35B GRAY IRON.
- 2- FRAME WT: 120 LBS. APP. PER SET.
- 3- COVER WT: 260 LBS. APP.

U.S. FOUNDRY & MFG. CORP.
MIAMI, FLORIDA

USF 5166 FRAME &
HY COVER

DWN. BY: A.M. | DATE:08/26/91

CHK. BY: | DWG. NO: A2605