

1 1/2 DIA. HOLE

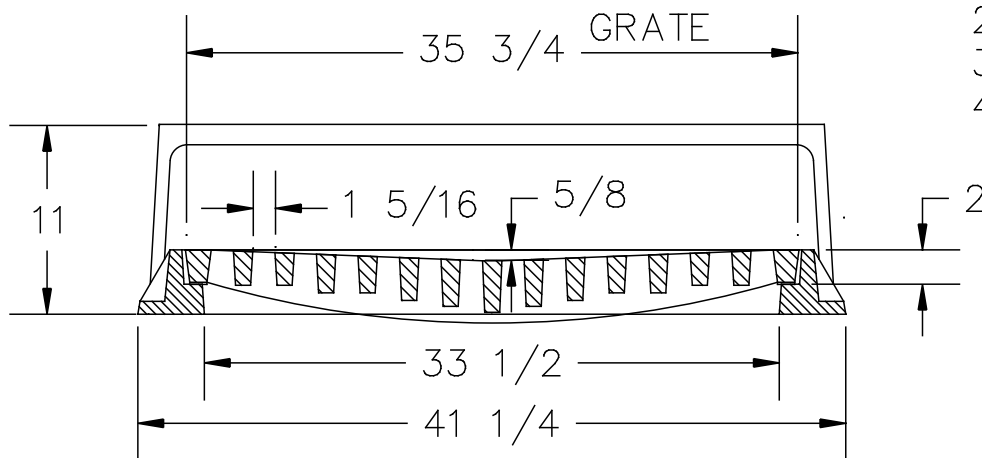

NOTES:

- 1- MATERIAL: ASTM-A48 CLASS 35B GRAY IRON.
- 2- FRAME WT: 190 LBS. APP.
- 3- GRATE WT: 265 LBS. APP.
- 4- HOOD WT: 220 LBS. APP.

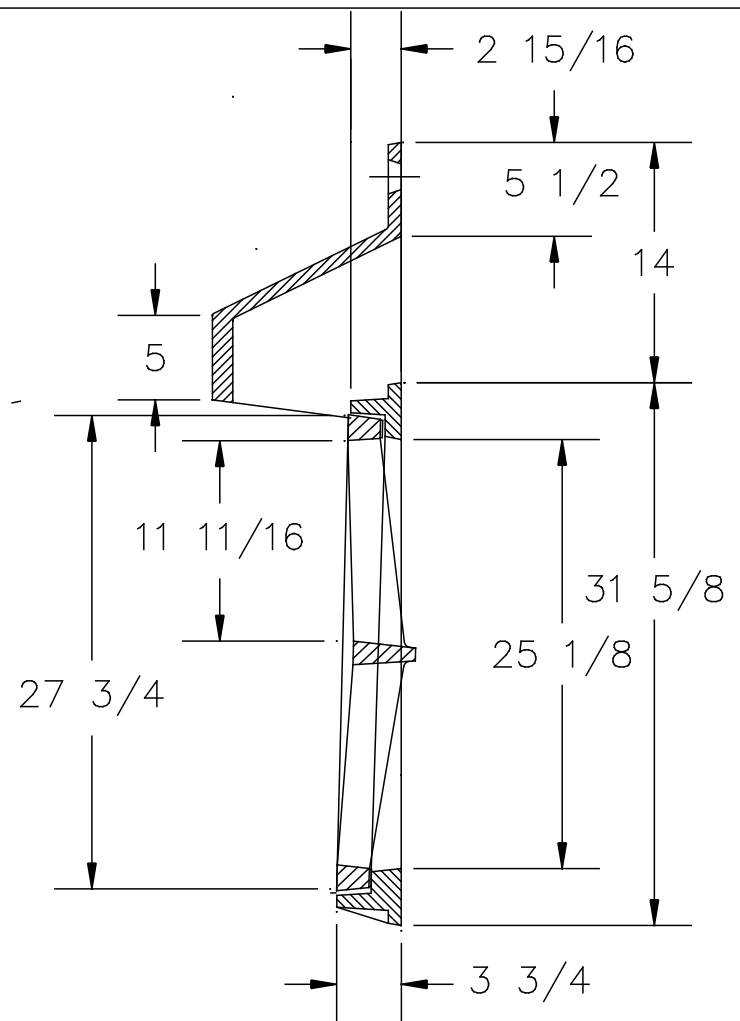
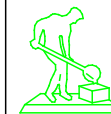

U.S. FOUNDRY & MFG. CORP.
MEDLEY, FLORIDA

USF 5145 FRAME AND 6213 GRATE

DWN. BY: DBB	SCALE: 1" = 12"	DATE: 6/16/97
CHK. BY:	DWG. NO: A0892-R	REV: