

1/2" ϕ X 2 1/2" LG.
GALVANIZED BOLTS

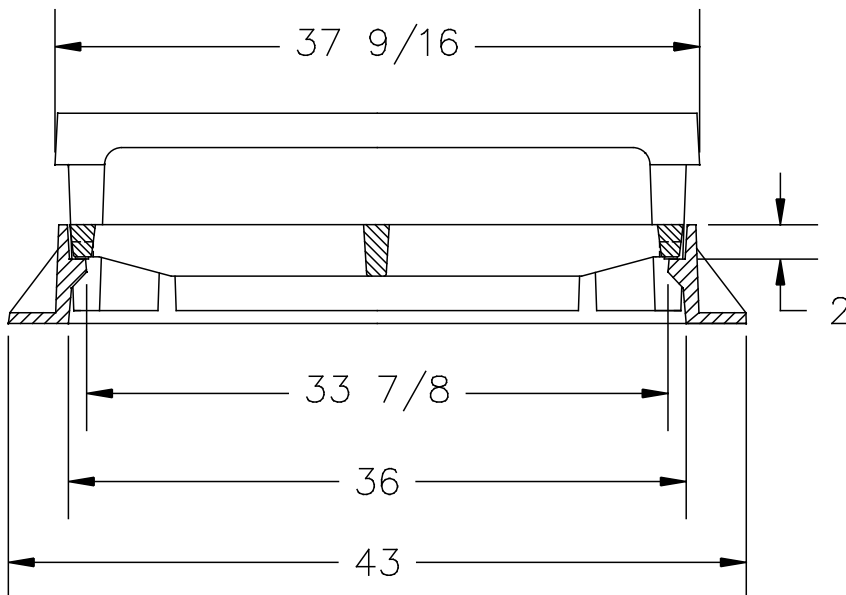

NOTES:

- 1- MATERIAL: ASTM-A48 CLASS 35B GRAY IRON.
- 2- FRAME WT: 195 LBS APP.
- 3- GRATE WT: 195 LBS APP.
- 4- HOOD WT: 125 LBS APP.

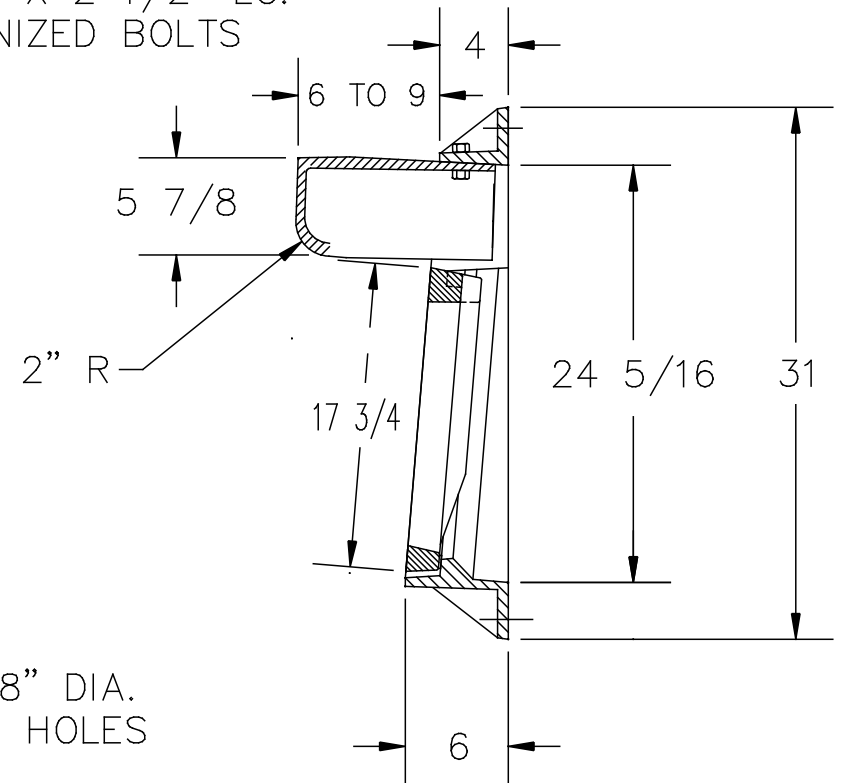
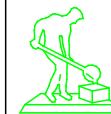

U.S. FOUNDRY & MFG. CORP.
MEDLEY, FLORIDA

USF 5130 FRAME & HOOD
& 6431 GRATE

DWN. BY: DBB	SCALE: 1"=1'-0"	DATE: 6/26/98
CHK. BY:	DWG. NO: A4140	REV: