

1/2" ϕ X 2 1/2" LG.
GALVANIZED BOLTS

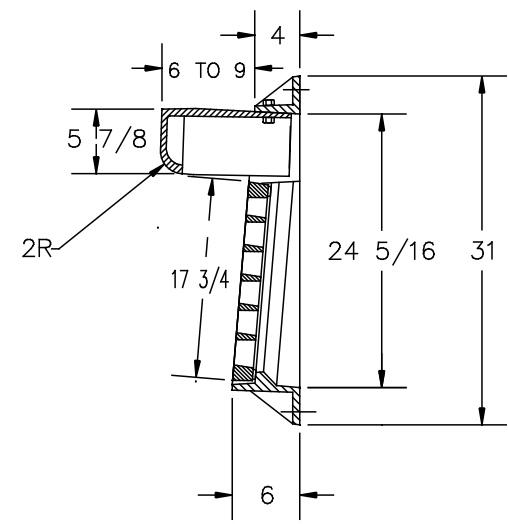

12 - 7/8" DIA.
ANCHOR HOLES

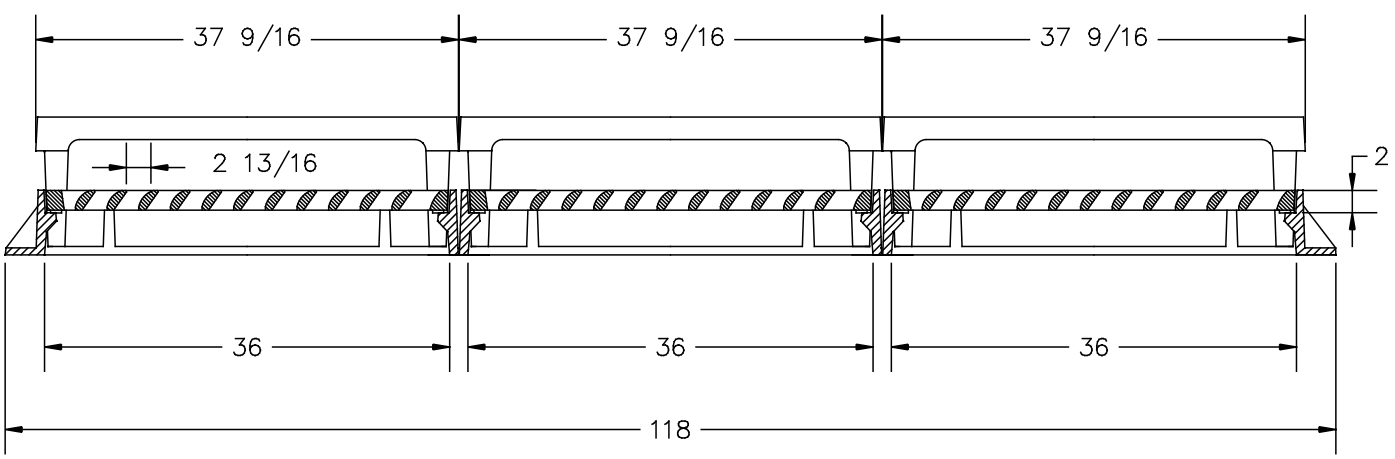

NOTES:

- 1- MATERIAL: ASTM A48
CLASS 30B GRAY IRON.
- 2- FRAME WT: 180 LBS. APP. EA.
- 3- GRATE WT: 155 LBS. APP. EA.
- 4- HOOD WT: 125 LBS. APP. EA.
- 5- LOADING: MEDIUM DUTY

 U.S. FOUNDRY & MFG. CORP. MEDLEY, FLORIDA		
USF 5130-3 FRAME & HOOD & 6021 GRATE		
DWN. BY: DBB	SCALE: 1"=1'-0"	DATE: 2/23/00
CHK. BY:	DWG. NO: A4844	REV: