

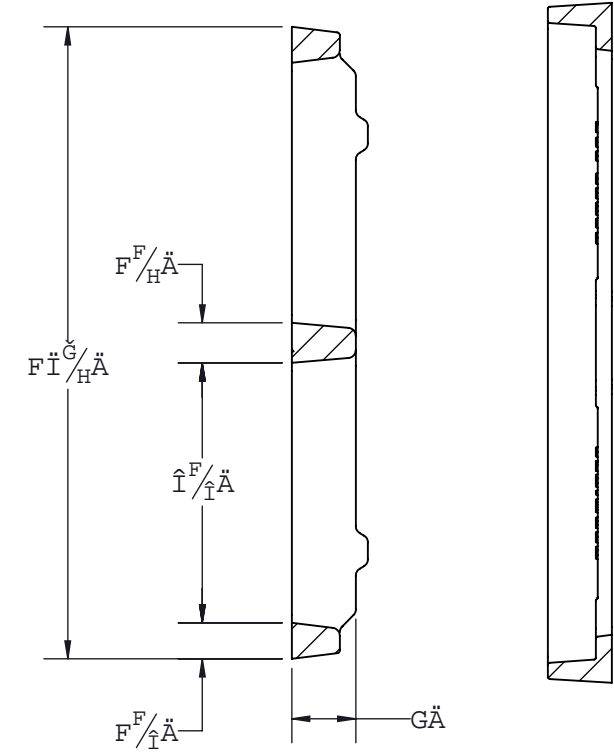

H:9B:CFA5HC B7CBH5B98 B H:68F5K B: 4GH:9GC@DFCD9FHC: 1'G':C1B8FM' A5BI:57HF B: 7CFD'5BMF9DFC817HC B B D5FH
 CF5G5K <C@K H:C1HH:9K F#H9B D9FA GGCBC: 1'G':C1B8FM' A5BI:57HF B: 7CFD'6DFC <6H98'1'G':C1B8FM' A5BI:57HF B:
 7CFD'F99FJ 9GH:9F <HHC A579A C8 >75HCBGHC 89G > B K H:C1HDF:CFBCH7 9'8F5K B: 4I B7CBHC@98 K <9B DF:8H8'K 9 > HG
 5B8 8A 9BGCBG5F9DFCJ 498:CF F9:9F9B79CB@M# 889) 1'G':C1B8FM5B'95: @A5BI:57HF B: 7CAD5BM

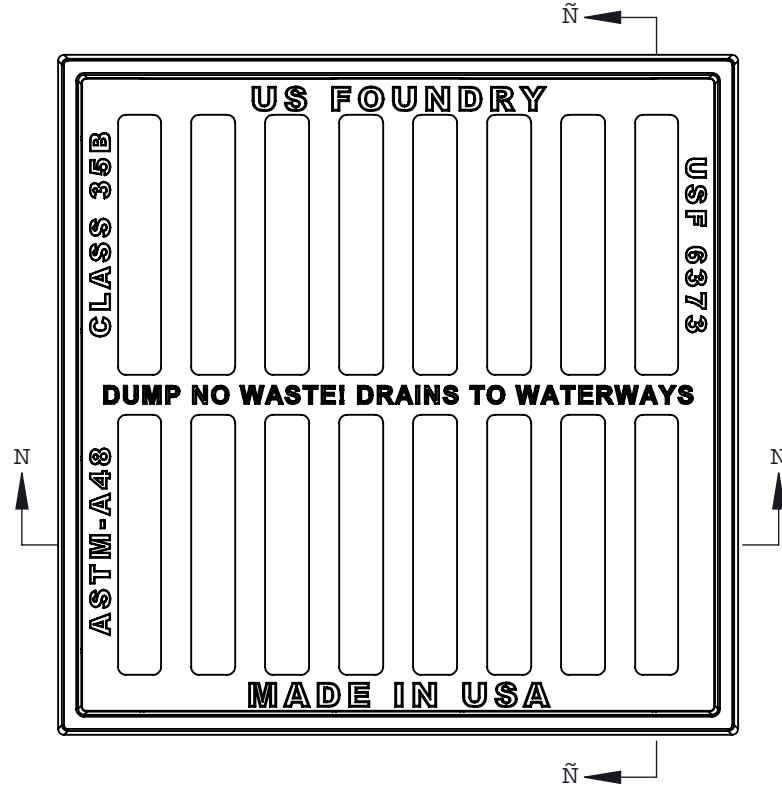

UÓÓØŠŠÁÑĚŇÁ

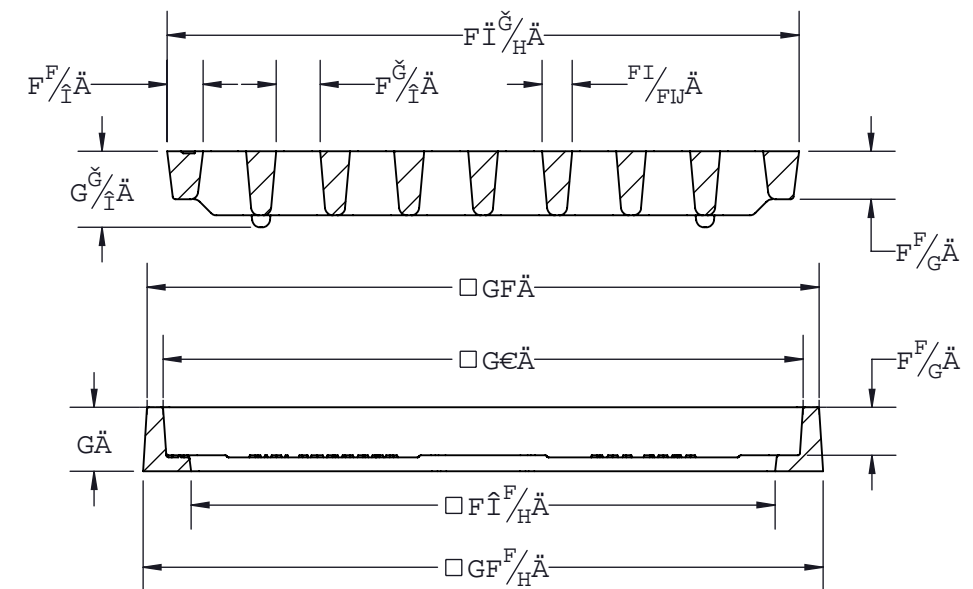

UÓÓØŠŠÁÑĚŇÁ



US FOUNDRY
AN EAGLE MANUFACTURING COMPANY

I G: (* + ' : fUa Y / ' * ' + ' ; fUHY

© 58 7 6G 7 5HC B.	J gcx{ 'F w{	: © K '5F95.	3980 ; 'lp
A 5H9F-5@	I tc{ 'Ecu'Kqp CCUJ VQ'O 528'Ercu'57D		
#9A.	655B :	8F5K B:	
: fUa Y	: 252437		
: fUHY	: 292655	85H9	: /45/35
5gg/a V'm	: 2623: 5	8F5K B 6M	QF
F9J	2 85H9	F9J 6M	E1CH9.
			6249

: cfU Wca d YHY d fcXi Whc ZY f b[d YUgY j lgh i gUh k k k "i gZci bXfmWca

71 gha Yf.8fuk jbl