

U.S. FOUNDRY & MFG. CORP.

<p style="writing-mode: vertical-rl; transform: rotate(180deg);">MADE IN U.S.A.</p> <p style="writing-mode: vertical-rl; transform: rotate(180deg);">U.S. FOUNDRY & MFG. CORP.</p> <p style="writing-mode: vertical-rl; transform: rotate(180deg);">MADE IN U.S.A. 840.16</p> <p style="text-align: center;">DATE</p>	<p style="writing-mode: vertical-rl; transform: rotate(180deg);">MADE IN U.S.A. 840.16</p> <p style="writing-mode: vertical-rl; transform: rotate(180deg);">U.S. FOUNDRY & MFG. CORP.</p> <p style="writing-mode: vertical-rl; transform: rotate(180deg);">MADE IN U.S.A. 840.16</p> <p style="text-align: center;">DATE</p>
---	--

5113

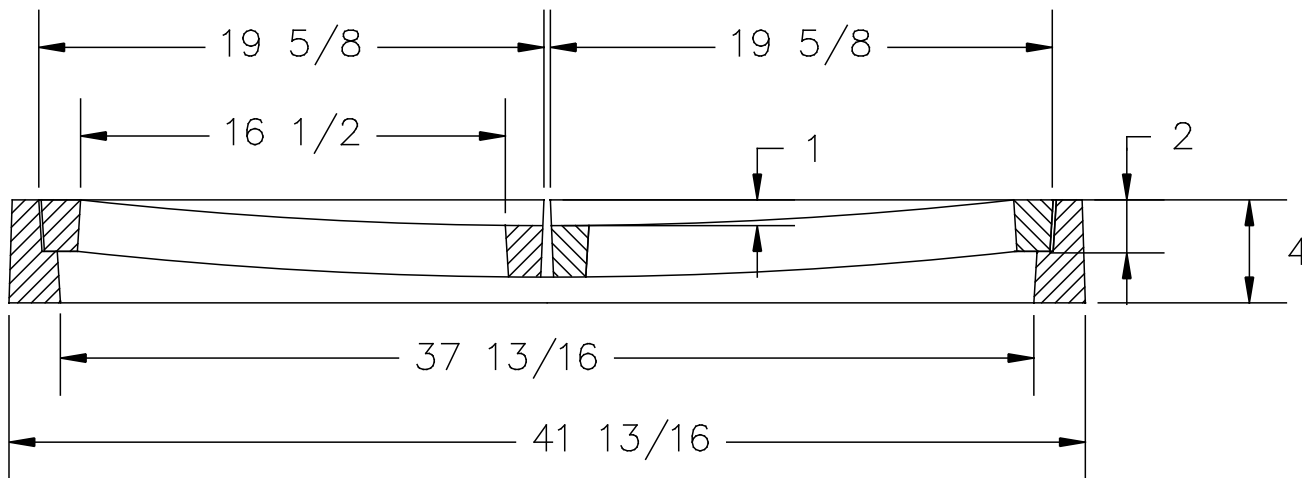
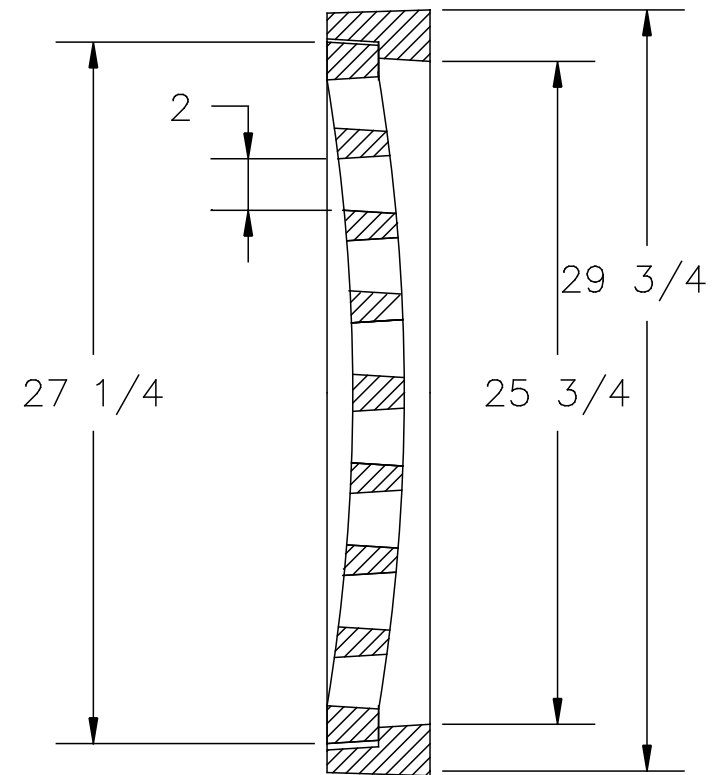

NOTES:

1. MATERIAL: ASTM-A48 CLASS 35B GRAY IRON.
2. FRAME WT: 220 LBS. APP.
3. GRATE WT: 250 LBS. APP.

U.S. FOUNDRY & MFG. CORP.
 MEDLEY, FLORIDA

USF 4616 FRAME & 6221 GRATE

DWN. BY: E.W.	SCALE: 1/8"=1"	DATE: 4/5/90
CHK. BY:	DWG. NO: A2296	REV: