

THE INFORMATION CONTAINED IN THIS DRAWING IS THE SOLE PROPERTY OF U.S. FOUNDRY & MANUFACTURING CORP. ANY REPRODUCTION IN PART OR AS A WHOLE WITHOUT THE WRITTEN PERMISSION OF U.S. FOUNDRY & MANUFACTURING CORP. IS PROHIBITED. U.S. FOUNDRY & MANUFACTURING CORP. RESERVES THE RIGHT TO MAKE MODIFICATIONS TO DESIGN WITHOUT PRIOR NOTICE. DRAWING IS UNCONTROLLED WHEN PRINTED. WEIGHTS AND DIMENSIONS ARE PROVIDED FOR REFERENCE ONLY © 2012 U.S. Foundry & Mfg. Corp. All Rights Reserved

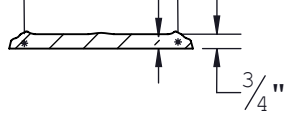

SECTION C-C
SCALE 1 : 10

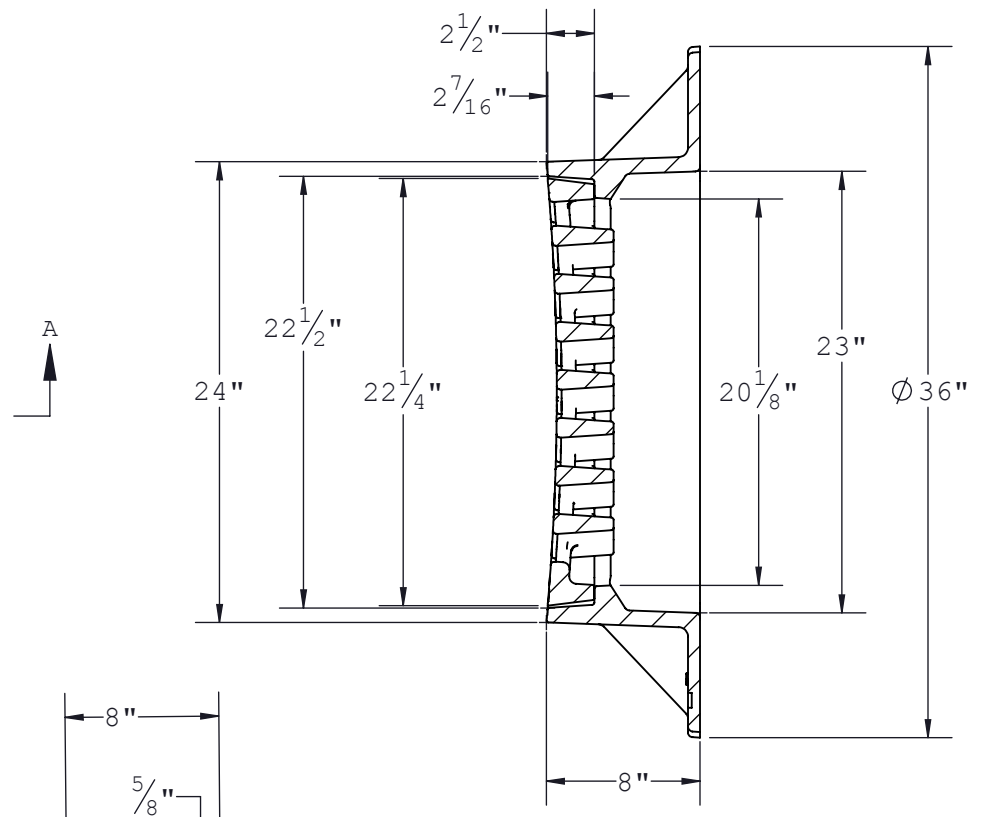
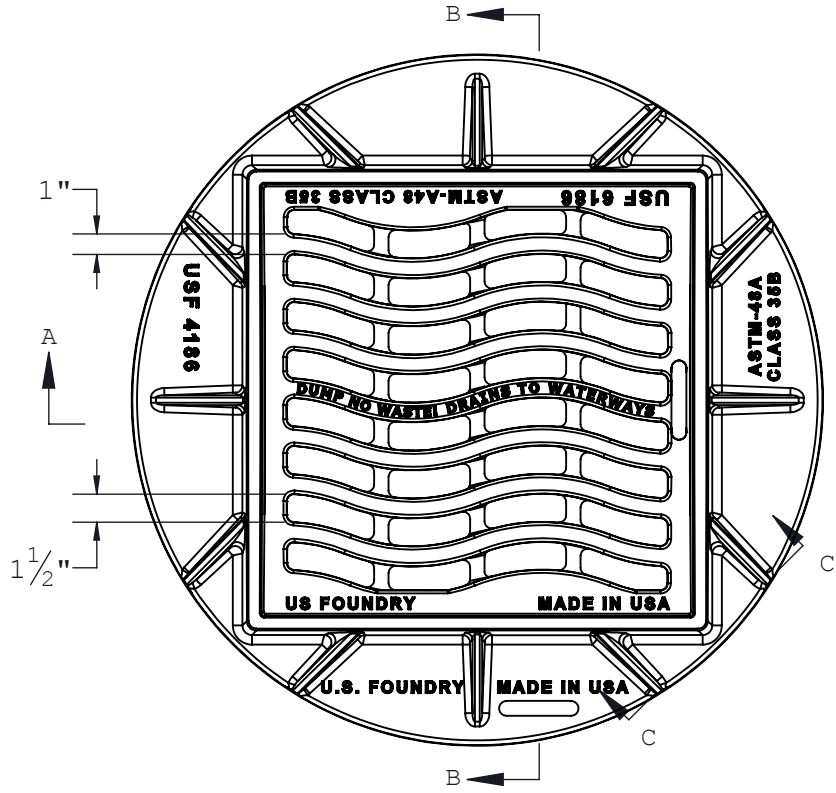
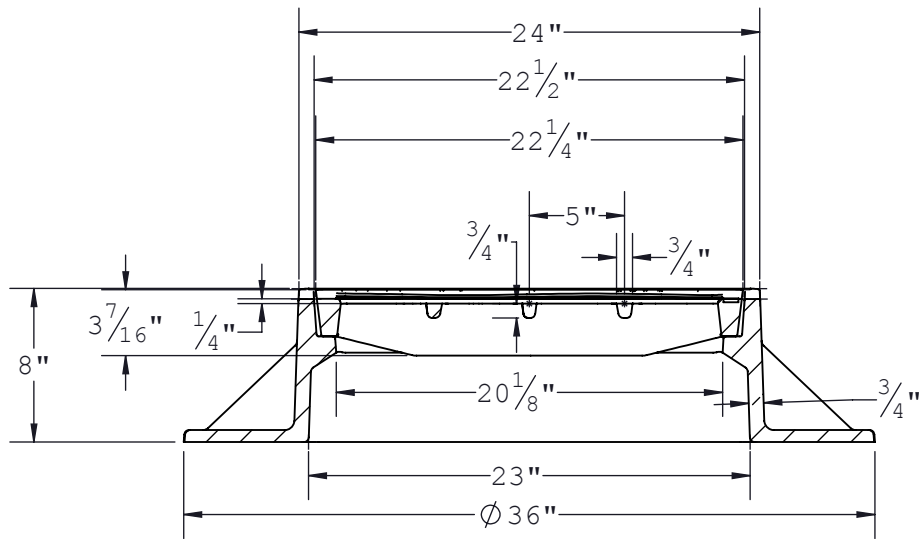

SECTION A-A

U.S. FOUNDRY & MFG. CORP.
 8351 NW 93rd Street, Medley, FL, 33166-2025
 ph: 1-800-432-9709; fax: 305-887-9429
 www.usfoundry.com
 © 2013 U.S. Foundry & Mfg. Corp. All Rights Reserved

USF 4186 Frame & 6186 Grate
[IN DOT, MWT]

LOAD CLASSIFICATION:	Heavy Duty	FLOW AREA:	225 in ²
MATERIAL:	Gray Cast Iron ASTM-A48 Class 35B		
ITEM:	BAAN #	DRAWING	
Frame	8030474	USF 4186-6186	
Grate	8076910	DATE	1/30/2013
Assembly	8040382	DRAWN BY	AB
REV	0	DATE	REV BY
			QUOTE #
			3736

Customer Drawing