

(2) - ϕ 5/8 x 3" LG.
S.S. HEX HEAD BOLTS

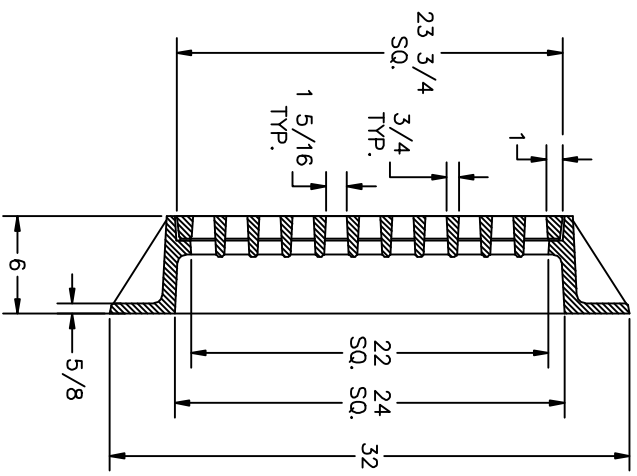

US FOUNDRY & MFG. CORP.
8351 NW 93rd Street, Medley, FL 33166-2025
ph: 1-800-432-9709; fax: 305-887-9429
www.usfoundry.com

© 2010 US Foundry & Mfg. Corp. All Rights Reserved

USF 4142 Frame & 6259 Grate
(USF4142=2xUSF4134-3(8030274); assy incl two 6259 Gr)

LOAD CLASSIFICATION: Heavy Duty	FLOW AREA=284.6in
MATERIAL: ASTM-A48 GRAY IRON	CLASS: 35B
Frame No: 8030272	WGHT: 350
Grate No: 8070145	SCALE: 1"=1"
Assembly No: 8040267	DATE: 4-3-09
UNLESS OTHERWISE NOTED WEIGHT IS IN POUNDS AND APPROXIMATED	DWN. BY: ULS
REV: DATE:	REV BY: QUOTE#