

3/8 TEXT  
RAISED 3/32 TYP.

LEVELING PADS (8)

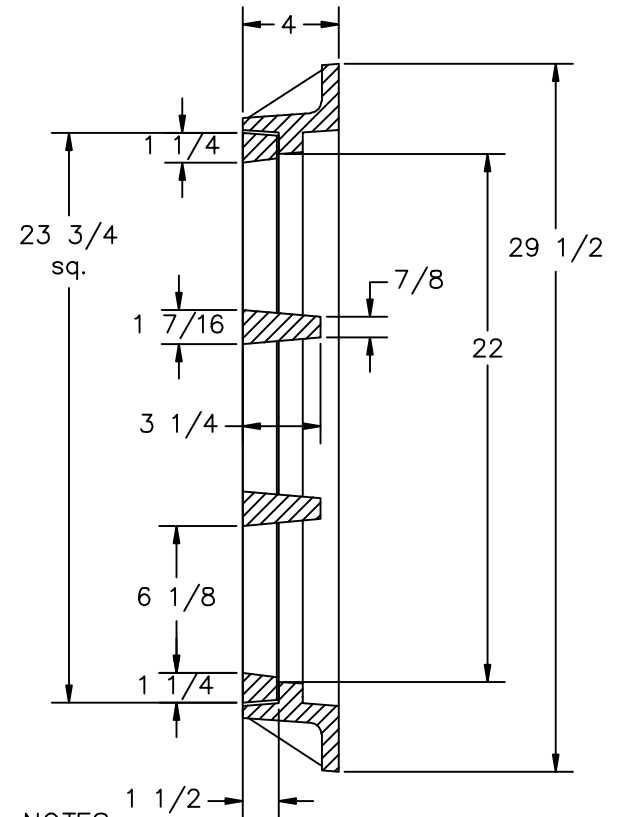

**NOTES:**

- 1- GRATE DESIGNED FOR ADA REQUIREMENTS..
- 2- OPEN AREA: 233. sq. in.
- 3- FRAME IS REVERSIBLE.
- 4- CLASSIFICATION: HEAVY DUTY

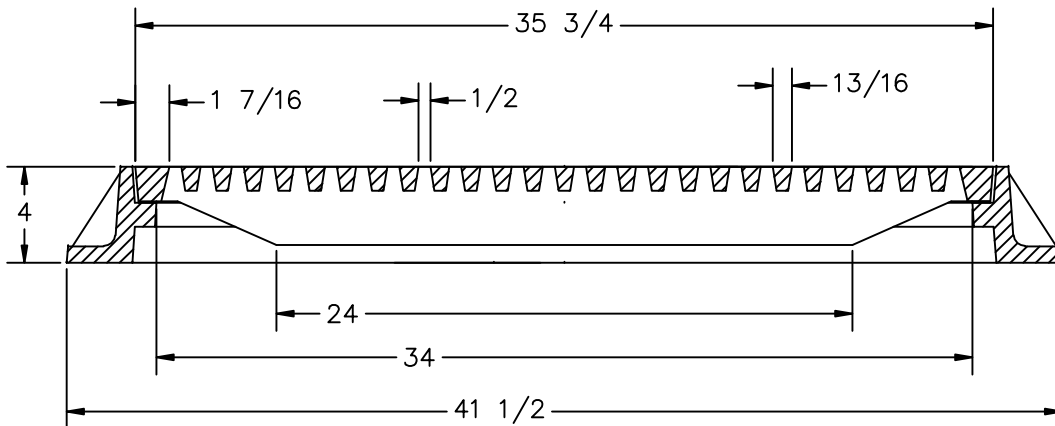

**U.S. FOUNDRY & MFG. CORP.**  
MEDLEY, FLORIDA

**DESCRIPTION:**

USF 4139 FRAME & 6002 GRATE

MATERIAL: ASTM-A48

GRAY IRON CLASS: 35B

FRAME WEIGHT: 165

GRATE WEIGHT: 190

UNLESS OTHERWISE NOTED WEIGHT IS IN POUNDS AND APPROXIMATED

DWN. BY: HJF  
SCALE: 1/8" = 1"

ITEM No:  
8040163

DWG. No:

DWG DATE:  
04-20-05

REV BY: HJF

REV: 2 DATE: 08-23-05 DESCRIPTION: WAS 8070411 DWG #. IS NOW 8040163

REV: 2