

(4) - $\phi 1/2$ " x 2" S.S. HEX HEAD BOLTS & PLATED WASHER

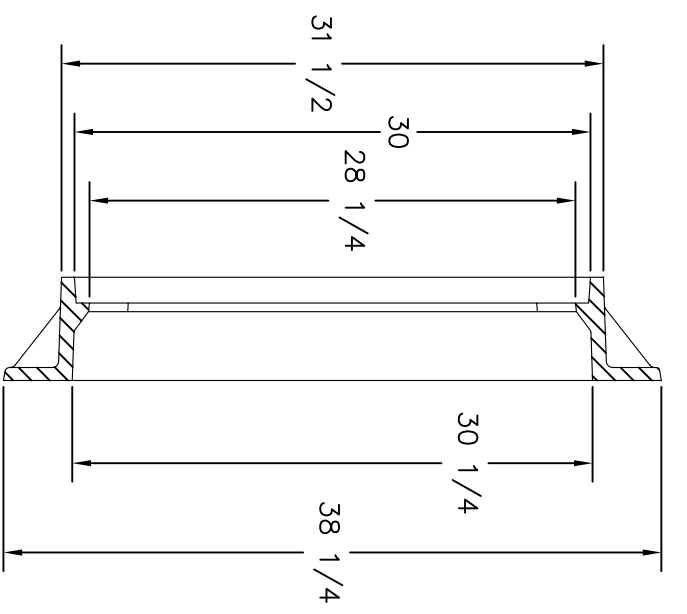
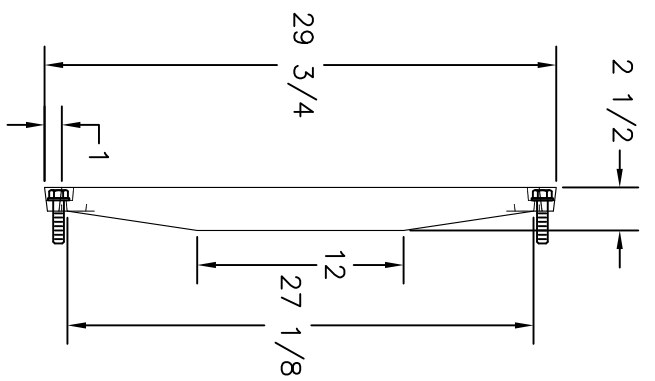

NOTE:
 1- MATERIAL: FRAME ASTM-A48 GRAY IRON
 CLASS35B & GRATE DUCTILE IRON, ASTM
 A-53677 65-45-12

US FOUNDRY & MFG. CORP.
 8351 NW 93rd Street, Medley, FL 33166-2025
 ph: 1-800-432-9709; fax: 305-887-9429
 www.usfoundry.com
 © 2010 US Foundry & Mfg. Corp. All Rights Reserved

USF 4107 FRAME & 6356 GRATE

LOAD CLASSIFICATION: Heavy Duty

| | | | |
|---|---------|----------|---------|
| MATERIAL: | | | |
| Frame No: | 8030316 | WGHT: | 267 |
| Grate No: | 9210047 | SCALE: | 1" = 1" |
| Assembly No: | 8040320 | DATE: | 97 |
| UNLESS OTHERWISE NOTED WEIGHT IS IN POUNDS AND APPROXIMATED | | DWN. BY: | ULS |
| REV: | DATE: | REV BY: | QUOTE# |