

(4) - 1" DIA. ANCHOR HOLES

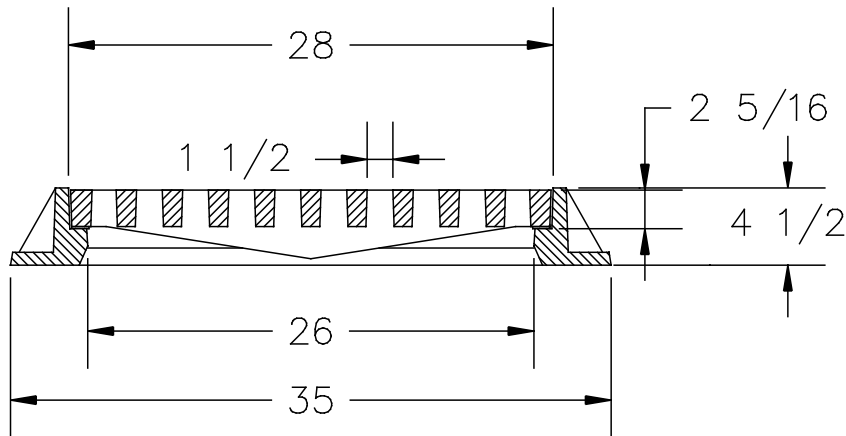

NOTES:

- 1- MATERIAL: ASTM-A48 CLASS 35B GRAY IRON.
- 2- FRAME WT: 210 LBS. APP.
- 3- GRATE WT: 155 LBS. APP.

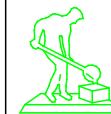

**U.S. FOUNDRY & MFG. CORP.**  
 MEDLEY, FLORIDA

USF 4105 FRAME &  
 6220 GRATE

DWN. BY: MR	SCALE: 1" = 1'	DATE: 9/29/80
CHK. BY:	DWG. NO: A0123	REV: