

H:9B:CFA5HC B7CBH5B98 B H:68F5K B: 4H:9QC@DFCD9FMC: 1'G:C1B8FM' A5BI:57HF B: 7CFD'5BMF9DFC8I7HC B B D5FH  
 CF5G5 K <C@K H:C1HH:9K F#H9B D9FA GGC B C: 1'G:C1B8FM' A5BI:57HF B: 7CFD'6DFC-6+98'1'G:C1B8FM' A5BI:57HF B:  
 7CFD'F90FJ 9GH:9F <HC A579A C8=75HC BGHC 89G= B K H:C1HDF CF BCH7 9'8F5K B: 4I B7CBHC@98 K <9B DF:8H98'K 9= <HG  
 5B8 8A 9BGC BG5F9DFCJ 498: CF F9:9F 9B79CB@M# 85% 1'G:C1B8FM5B'95: @A5BI:57HF B: 7CAD5BM

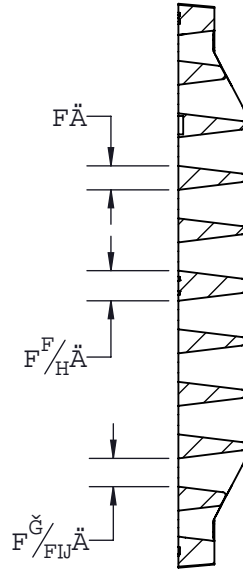

UÓÓÚØŠŠÁNĚŇ

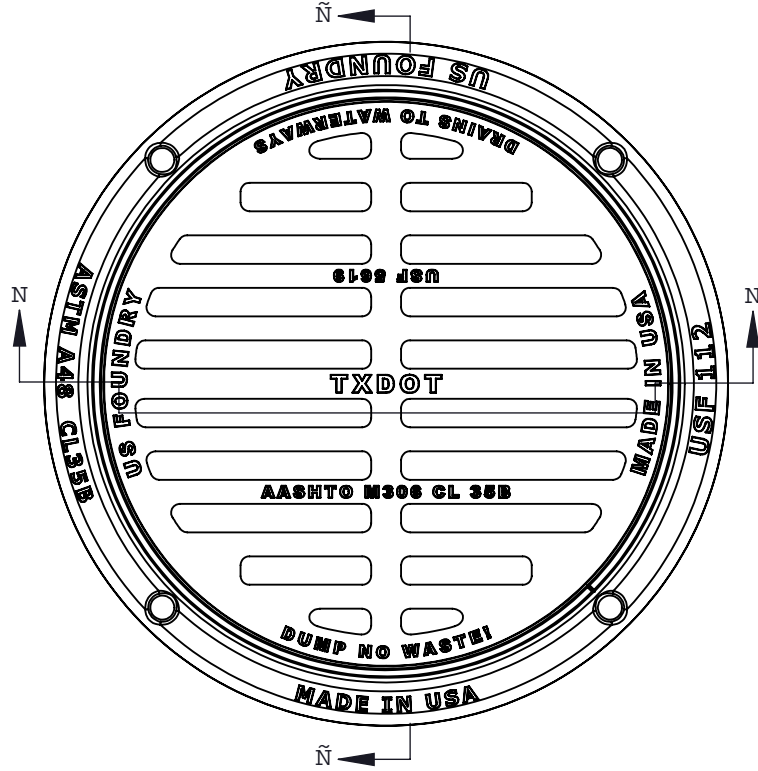
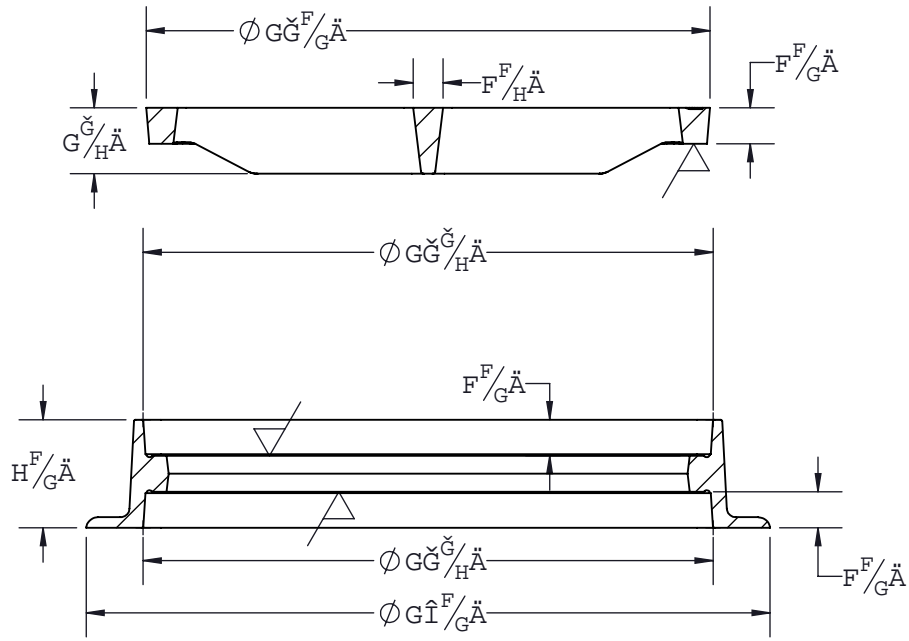
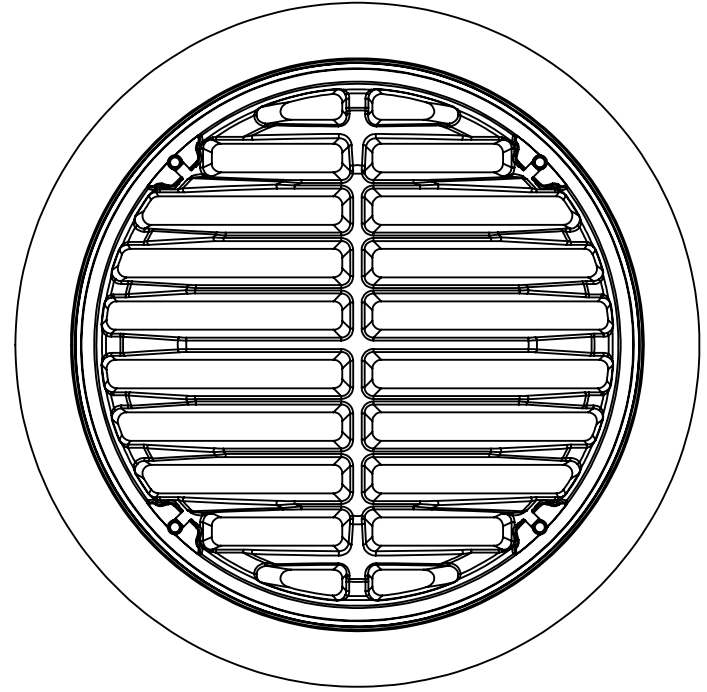

UÓÓÚØŠŠÁNĚŇ

**US FOUNDRY**  
 AN EAGLE MANUFACTURING COMPANY

I G: '%%&' F]b[ / ' ) \* %- ; fUHŸ

© 58 F5HB: . CCUI VQ/O528/32'J gex{ 'F w{ : © K '5F95. 3840'lp
A 5H9F-5@ I tc{ 'Ecu'Kqp CUVO/C6: 'Encu'57D
#9A. 655B' 8F5K B:
F]b[ : 244774
; fUHŸ : 292988
85HP 71: 4237
8F5K B'6M WNUICD
F'9J 2 85HP F'9J 6M E1CH9.

: cfU Wca d'YHŸ d'fcXi WhcZY]b[ 'd'YUgŸ j ]gŸhi gUh k k k "i gZci bXfm'Wca

71 gŸca Yf.8fuk ]b[